

alea

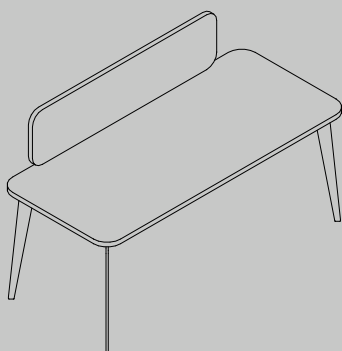

operativi | workstations | systèmes | operatives

BLADE



Un design fortemente distintivo

segnato da linee morbide
e avvolgenti esaltate da
combinazioni di colore uniche
ed originali



A strongly distinctive
design, marked by soft
and enveloping lines
enhanced by unique
and original colour
combinations



Un design distinctif,
marqué de lignes
douces, enveloppantes,
agrémentées de
combinaisons de
couleurs uniques et
originales

Un diseño muy
distintivo, marcado
por líneas suaves y
envolventes, realizadas
por combinaciones de
color únicas y originales

/design

La peculiarità formale di Blade si esprime nella gamba in acciaio di 12 mm di spessore tagliata a laser, che si pone alla vista dell'osservatore come una lama: essenziale, forte, aggressiva ed elegante allo stesso tempo. La struttura della scrivania si compone di soli quattro elementi: due gambe "a ponte" e due longheroni.



***I design** Blade's formal peculiarity is expressed in its 12 mm (8/16") thick laser-cut steel leg, which appears like a blade: essential, strong, aggressive and elegant at the same time. The desk structure is made of only four elements: two angle open legs and two metal beams.*

***I design** la particularité formelle de Blade est exprimée dans sa jambe en acier de 12 mm d'épaisseur, coupée au laser. Elle est perçue (par le spectateur) comme une lame: essentielle, forte, agressive et élégante à la fois. La structure du bureau se compose de seulement quatre éléments: deux pieds en forme de «pont» et deux longerons.*

***I diseño** Una peculiaridad formal de Blade está expresada en sus 12 mm de espesor de la pierna de acero de corte laser, que aparece como una hoja: esencial, fuerte, agresiva y elegante al mismo tiempo. El escritorio está hecho de solo cuatro elementos: dos patas abiertas y dos vigas metálicas.*



/armonia

La collezione Blade con le sue scrivanie freestanding, dà un tocco originale e ricercato agli ambienti di lavoro. Gli angoli dei piani sono preferibilmente arrotondati per armonizzarsi con il design della gamba.



l'harmony Blade collection with its freestanding desks gives an original and refined touch to the workplace. The corners of the tops are preferably rounded to match the design of the leg.

l'harmonie la collection Blade, avec ses bureaux indépendants, donne une touche originale et raffinée au lieu de travail. Les coins des plans de travail sont de préférence arrondis pour s'harmoniser avec le design du pied.

l'armonía la colección Blade con sus escritorios independientes le da un toque original y refinado al lugar de trabajo. Las esquinas de las partes superiores se redondean para coincidir con el diseño de la pata.







l optimization Blade desks can be supported by lateral service units with metal feet and handles integrated into the door. The solution with the aligned structural units (plug) ensures a perfect space optimization.

l optimisation les bureaux Blade peuvent être supportés par des conteneurs latéraux posés sur des pieds en métal. Les portes sont munies d'une poignée intégrée en métal. La solution avec les conteneurs structurels alignés offre une colonne vertébrale pour l'aménagement qui assure l'optimisation parfaite de l'espace.

l optimización las mesas de Blade pueden ser soportadas por unidades de servicio laterales por pies de metal y agarraderas de metal integradas dentro de las puertas. La solución con las unidades estructurales alineadas (enchufe) garantiza una optimización del espacio perfecta.



/ottimizzazione

Le scrivanie Blade possono essere supportate da contenitori laterali con piedi in lamiera di acciaio e maniglia in metallo integrata alle ante. La soluzione con i contenitori strutturali allineati (spina) garantisce una perfetta ottimizzazione degli spazi.





/bench face-to-face workstations feature unique desktops designed to accommodate screen dividers.

/bench les postes de travail en face-à-face sont dotés de plans de travail uniques, conçus pour recevoir les écrans de séparation.

/bench las estaciones de trabajo cara a cara cuentan con escritorios únicos diseñados para acomodar divisores de pantalla.



/bench

Le postazioni di lavoro face-to-face sono realizzate con piani scrivania unici predisposti ad accogliere, gli screen dividers.





/screen

Gli screen vengono fissati ai top scrivania con appositi perni in metallo che, da sotto il piano lavoro, agganciano e stabilizzano il pannello senza che alcuna ferramenta sia visibile. Gli screen, disponibili in vari materiali, ripropongono le forme sagomate e curve di top e gamba.

I screens screens are fixed onto the desktop with special metal pivots which, from below the worktop, hook and stabilise the panel without any visible hardware. The screens, available in various materials, reproduce the shaped and curved forms of top and leg.

I écrans les écrans sont fixés aux plateaux des bureaux à l'aide d'épingles métalliques spéciales, qui, sous le plan de travail, stabilisent l'écran de manière invisible. Les écrans, sont disponibles dans divers matériaux, l'arrondi reproduit les formes du plan de travail et de la pied.

I paneles Los paneles se fijan al escritorio con pivotes de metal especiales que, desde debajo de la encimera, enganchan y estabilizan el panel sin ningún hardware visible. Las pantallas, disponibles en varios materiales, reproducen las formas curvas de la parte superior y la pierna.







***I returns** desks can be equipped with hanging returns. Blade top assembly to the structure is extremely easy and quick. There are no screws but special pivots which easily hook onto the desk structure. Tops are fixed by pressure.*

***I retours** les bureaux peuvent être équipés d'un retour accroché. L'assemblage des plans de travail de Blade à la structure est extrêmement simple et rapide et se réalise sans vis. Les plans sont fixés par une simple pression avec des broches spéciales qui s'accrochent facilement.*

***I alas** los escritorios pueden equiparse con alas suspendidas. El ensamblaje superior de Blade a la estructura es extremadamente fácil y rápido. No hay tornillos sino pivotes especiales que se enganchan fácilmente en la estructura del escritorio. Las tapas están fijadas por presión.*



/dattilo

Le scrivanie possono essere dotate di dattilo agganciati. L'assemblaggio dei piani Blade alla struttura è estremamente semplice e rapido. Non ci sono viti ma appositi perni che si agganciano facilmente. I piani vengono fissati a pressione.



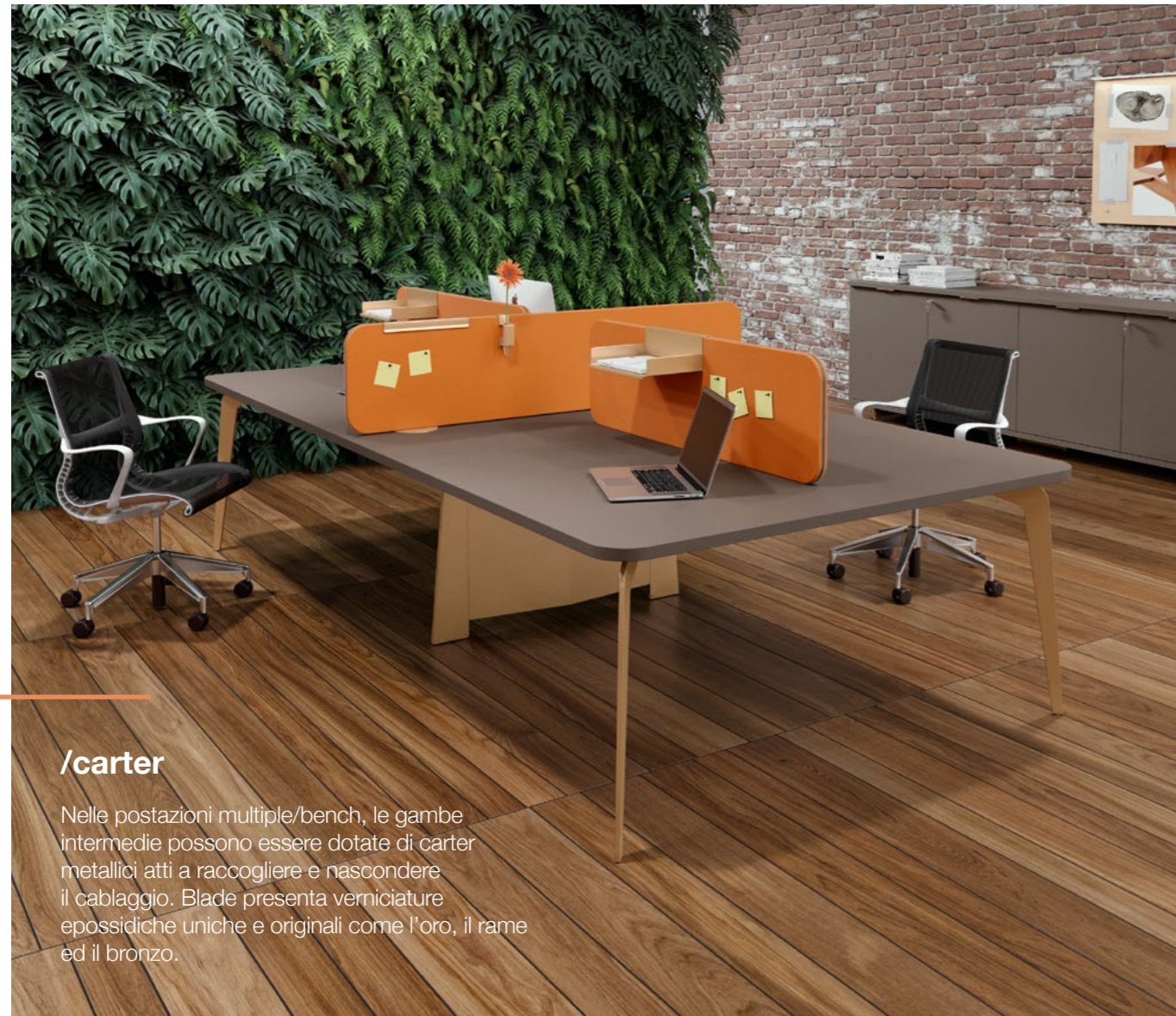

/carter

Nelle postazioni multiple/bench, le gambe intermedie possono essere dotate di carter metallici atti a raccogliere e nascondere il cablaggio. Blade presenta verniciature epossidiche uniche e originali come l'oro, il rame ed il bronzo.

***I cable risers** in multiple workstations and benches, the intermediate legs can be equipped with metal cable risers designed to collect and hide the electrification. Blade presents unique and original epoxy paints such as gold, copper and bronze.*

***I carters** dans les postes de travail multiples/benches, les pieds intermédiaires peuvent être équipés de carters métalliques pour collecter et masquer le câblage. Blade propose des peintures époxy originales telles que l'or, le cuivre et le bronze.*

***I cubiertas** en múltiples estaciones de trabajo y bancos, las patas intermedias pueden equiparse con cubiertas metálicas para recoger y esconder los cables. Blade presenta pinturas epóxicas únicas y originales como oro, cobre y bronce.*





/muovere

Gli screen laterali dei bench sono disponibili anche nella versione mobile con supporti metallici tondi che sostengono il pannello sopra il piano. Tutti gli screen Blade in tessuto puntaspilli si completano con una famiglia dedicata di accessori in metallo verniciati nella stessa finitura della struttura.

***I move** lateral screens for benches are also available in the movable version with round metal bases that support the panel above the top. All pinnable screens can come equipped with a dedicated series of metal accessories painted in the same finish as the structure.*



***I déménager** les écrans latéraux des benches sont également disponibles dans la version mobile avec des supports en métal ronds posés sur le plan de travail. Tous les écrans de Blade en tissu punaisable peuvent être complétés par une famille d'accessoires en métal peints dans la même couleur que celle de la structure.*

***I mover** las pantallas laterales también están disponibles en la versión móvil con bases de metal redondeadas que soportan el panel encima de la base. Todas las pantallas pueden venir equipadas con distintas series de accesorios de metal pintados en el mismo acabado que la estructura.*



/spazi direzionali

Blade arreda gli spazi direzionali con armonia ed eleganza: la scrivania con piani stondati si abbina al mobile di servizio su ruote e alla credenza con piedi metallici e maniglie abbiniate al colore della struttura.



/executive spaces

Blade furnishes executive spaces with harmony and elegance: the desk with rounded top is combined with the independent service unit supported by wheels and the storage with metal feet and handles matching the colour of the structure.

/espaces directionnels

Blade permet d'aménager des espaces directionnels avec harmonie et élégance. Le bureau avec ses plateaux aux angles arrondis est combiné avec la desserte de service sur roulettes et la crédence, grâce aux pieds et poignées en métal assortis à la couleur de la structure du bureau.

/espacios ejecutivos

Blade proporciona espacios ejecutivos con armonía y elegancia: el tablero con bordes redondeados está combinado con una unidad de servicio independiente soportada por ruedas y la unidad de almacenamiento con patas de metal y agarraderas que hacen juego con el color de la estructura.



/contenitori

Blade presenta una serie di contenitori dedicati. Le ante hanno larghezza 70 cm e il top di finitura si espone frontalmente ad allinearsi alla maniglia stessa.



I storage Blade introduces a series of dedicated storage. The door width is 70 cm (27 9/16") and the top is frontally exposed to align with the door handle.

I conteneurs Blade présente une série de conteneurs dédiés. Les portes ont une largeur de 70 cm et le plan débordé sur l'avant pour l'aligner avec la poignée.

I almacenamiento Blade presenta una serie de almacenamiento dedicado. La puerta mide 70 cm y la parte superior está expuesta frontalmente para alinearse con la manija de la puerta.







Elettrificazione per la scrivania freestanding: top access, canale portacavi, cestello portacavi, vertebra o guaina per elettrificazione verticale.



Cable management for freestanding desks: top access, metal tray, metal basket, cable management spine or cable tidy sleeving.

L'électrification pour le bureau indépendant: top access, goulotte passe cables en acier, panier passe cables en fil d'acier, vertèbre ou gaine pour l'électrification verticale.

Gestión de cables para escritorios independientes: top access, viga portacables, viga portacables en rejilla de acero, canalización salida de cables o cubierta flexible para cables.

Elettrificazione per la scrivania face-to-face: top access, canale portacavi doppio, vertebra o guaina per elettrificazione verticale.



Cable management for face-to-face workstations: top access, double metal tray, double metal basket, cable management spine or cable tidy sleeving.

L'électrification pour le bureau face-à-face: top access, goulotte passe cables en acier, panier passe cables en fil d'acier, vertèbre ou gaine pour l'électrification verticale.

Gestión de cables para estaciones de trabajo facetadas: top access, viga portacables, viga portacables en rejilla de acero, canalización salida de cables o cubierta flexible para cables.

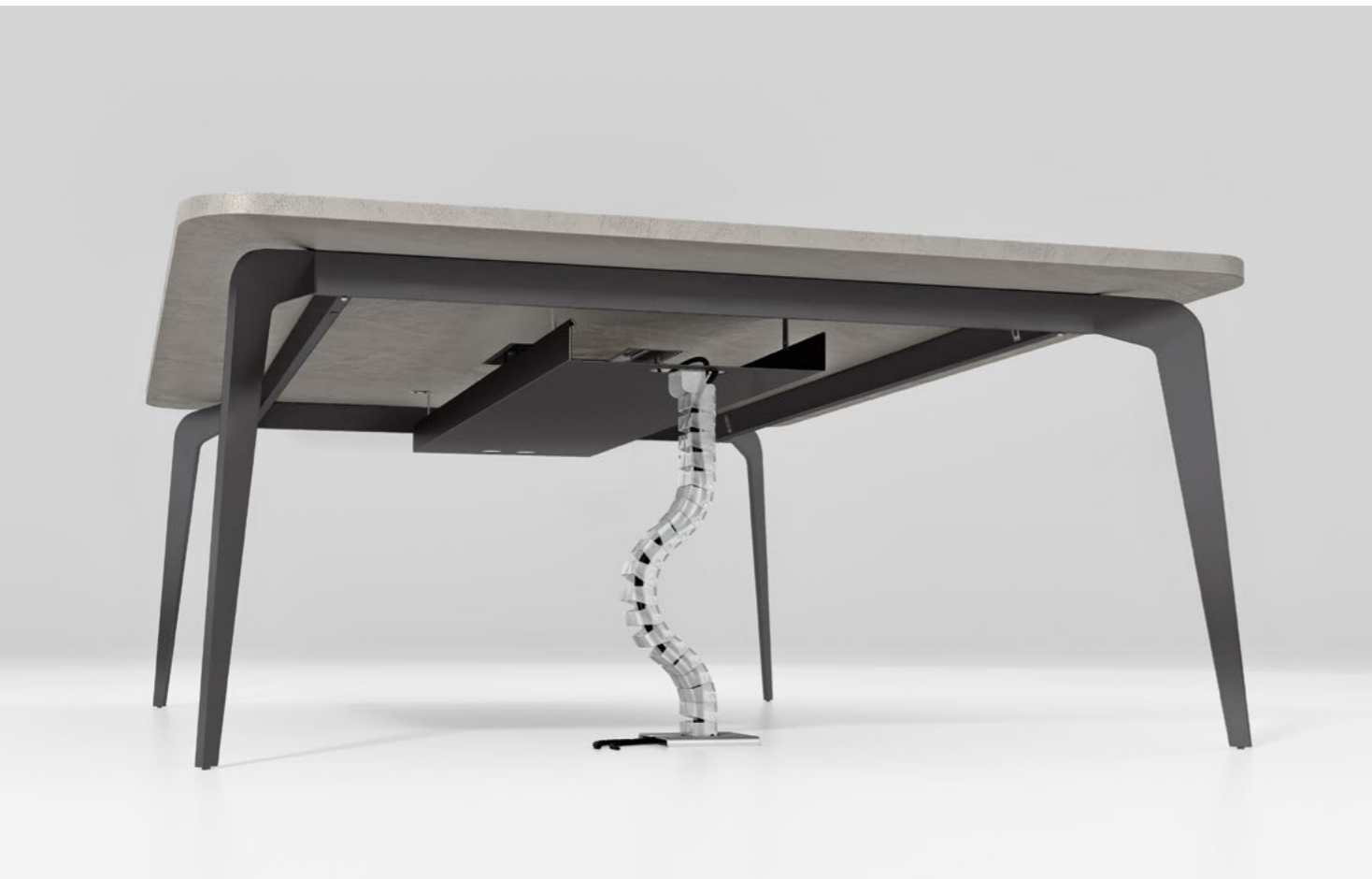



Elettrificazione per bench:
top access, canale
portacavi doppio, coppia
di carter metallici per
elettrificazione verticale.



*Cable management for
benches: top access,
double metal tray,
cable riser.*

*L'électrification du
bench: top access,
goulotte passe cables
en acier, paire de
carter métalliques
pour l'électrification
verticale.*

*Gestión de cables
para bancos:
top access, viga
portacables,
canalización salida
cables.*

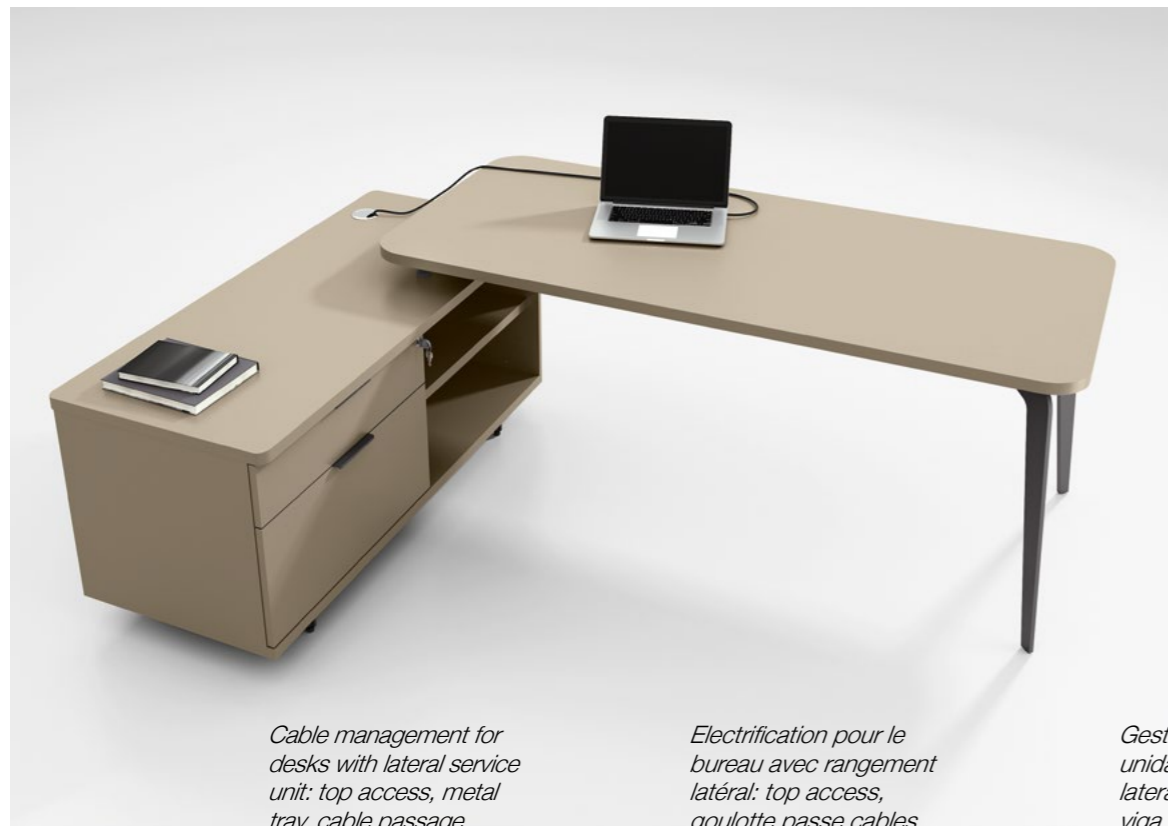

Cable management for desks with lateral service unit: top access, metal tray, cable passage through the top and back of the storage unit, use of the hollow back space for vertical cable management.

Electrification pour le bureau avec rangement latéral: top access, goulotte passe cables, passage du câble sur le haut et le bas du conteneur, exploitation du compartiment du câble à l'arrière pour l'électrification verticale.

Gestión de cables para unidades de servicio laterales: top access, viga portacables, paso de cables a través de la parte superior y posterior de la unidad de almacenamiento.



Elettrificazione per la scrivania con contenitore laterale: top access, canale portacavi, passaggio cavi su top e fondo del contenitore, sfruttamento del vano cavo della schiena per elettrificazione verticale.



Scrivanie | desks | bureaux | mesas

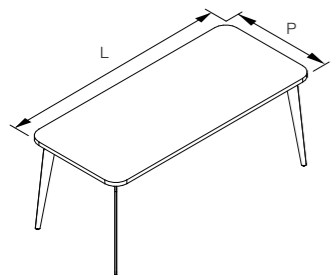

H 73,4 28 14/16"					
	L 120 47 4/16"	L 140 55 2/16"	L 160 63"	L 180 70 14/16"	L 200 78 12/16"
P 80 31 8/16"	•	•	•	•	•
P 90 35 7/16"				•	•

Scrivanie per contenitore | desks for service unit | bureaux pour meuble retour | mesas para mueble auxiliar

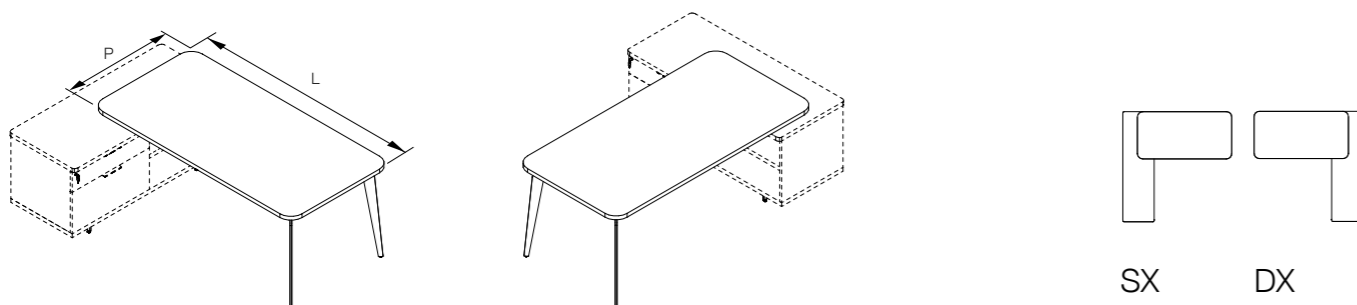

H 73,4 28 14/16"					
	L 120 47 4/16"	L 140 55 2/16"	L 160 63"	L 180 70 14/16"	L 200 78 12/16"
P 80 31 8/16"	•	•	•	•	•

Modesty panel | modesty panel | voile de fond | faldón

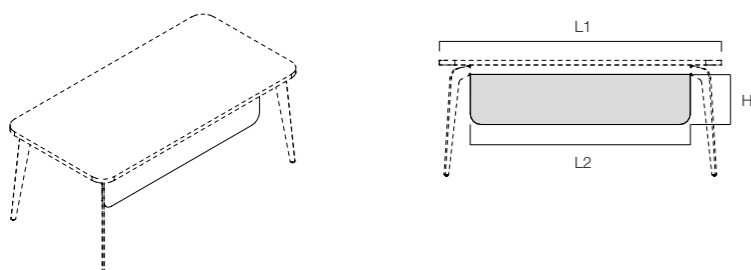

H 32 12 10/16"					
	L1 120 47 4/16" L2 80 31 8/16"	L1 140 55 2/16" L2 100 39 6/16"	L1 160 63" L2 120 47 4/16"	L1 180 70 14/16" L2 140 55 2/16"	L1 200 78 12/16" L2 160 63"
P 1,8 11/16"	•	•	•	•	•

Dattilo indipendenti | free standing returns | retours indépendants | alas independientes

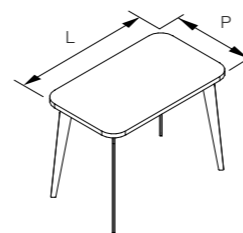

H 73,4 28 14/16"					
	L 80 31 8/16"	L 100 39 6/16"	L 120 47 4/16"		
P 60 23 10/16"	•	•	•		

Dattilo agganciati | hanging returns | retours accrochés | alas suspendidas

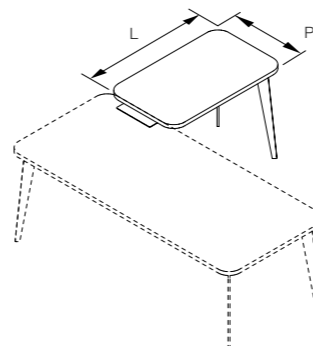

H 73,4 28 14/16"					
	L 80 31 8/16"	L 100 39 6/16"	L 120 47 4/16"		
P 60 23 10/16"	•	•	•		

Bench 2 posti | bench 2 workstations | bench à 2 postes | bench a 2 puestos

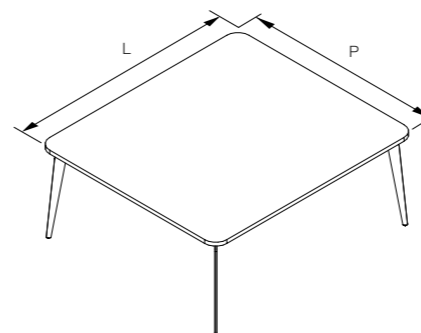

H 73,4 28 14/16"					
	L 120 47 4/16"	L 140 55 2/16"	L 160 63"	L 180 70 14/16"	L 200 78 12/16"
P 160 63"	•	•	•	•	•

Bench 4 posti | bench 4 workstations | bench à 4 postes | bench a 4 puestos

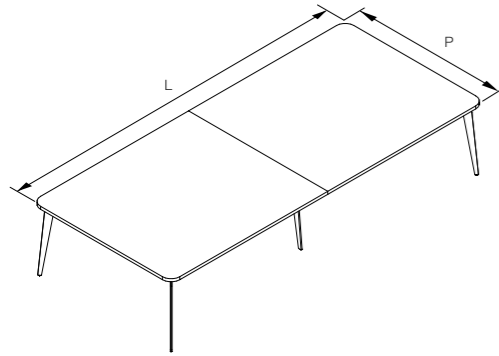

H 73,4 28 14/16"					
	L 240 94 8/16"	L 280 110 4/16"	L 320 126"	L 360 141 12/16"	L 400 157 8/16"
P 160 63"	•	•	•	•	•

Bench 2 posti per contenitore | bench 2 workstations for service unit | bench à 2 postes pour meuble retour | bench a 2 puestos para mueble auxiliar

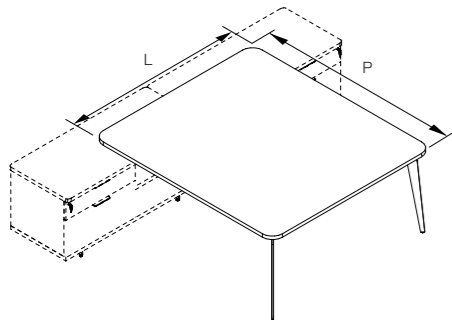

H 73,4 28 14/16"					
	L 120 47 4/16"	L 140 55 2/16"	L 160 63"	L 180 70 14/16"	L 200 78 12/16"
P 160 63"	•	•	•	•	•

Tipologie screen | screen type | type d'écran | tipo de panel

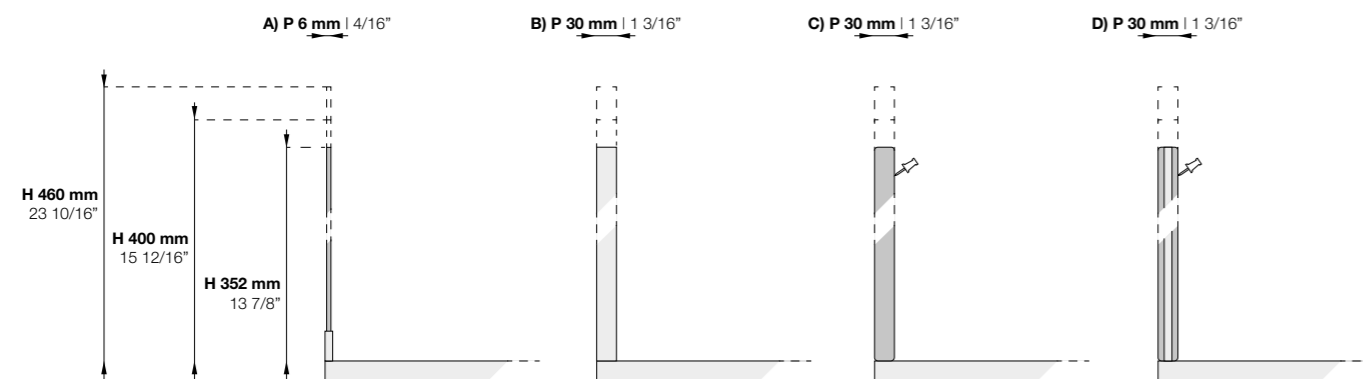

A) metacrilato | acrylic | méthacrylate | metacrilato **B) melaminico o gofrato** | Italian melamine or embossed | mélaminé ou gaufré | melaminico o lacado **C) tessuto puntaspilli** | pinnable fabric | tissu punaisable | tejido pinchable **D) sandwich melaminico e tessuto puntaspilli** | sandwich Italian melamine and pinnable fabric | tissu punaisable avec ame et bord en melaminé | melaminico tapizado en los 2 lado

Screen frontali per scrivania singole | frontal screens for freestanding desks | écrans frontaux pour bureaux | paneles frontales para mesas

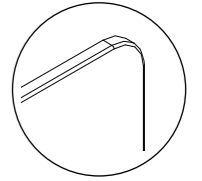
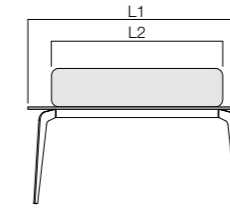
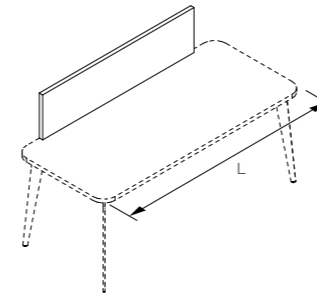

disponibile con 2 o 4 angoli raggiati
available with 2 or 4 rounded corners
disponible avec 2 ou 4 coins ronds
disponible con 2 o 4 cantos redondeados

	L1 120 47 4/16" L2 77 30 3/16"	L1 140 55 2/16" L2 97 38 1/16"	L1 160 63" L2 117 45 15/16"	L1 180 70 14/16" L2 137 53 13/16"	L1 200 78 12/16" L2 157 61 11/16"
	•	•	•	•	•

Screen frontali per bench | frontal screens for benches | écrans frontaux pour bench | paneles frontales para bench

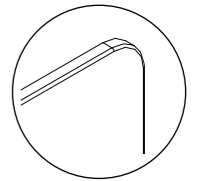
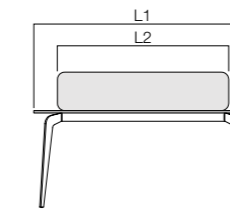
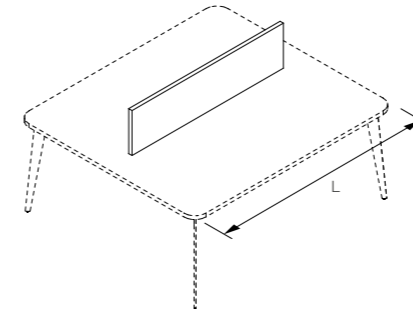

disponibile con 2 o 4 angoli raggiati
available with 2 or 4 rounded corners
disponible avec 2 ou 4 coins ronds
disponible con 2 o 4 cantos redondeados

	L1 120 47 4/16" L2 77 30 3/16"	L1 140 55 2/16" L2 97 38 1/16"	L1 160 63" L2 117 45 15/16"	L1 180 70 14/16" L2 137 53 13/16"	L1 200 78 12/16" L2 157 61 11/16"
	•	•	•	•	•

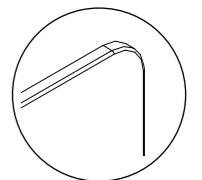
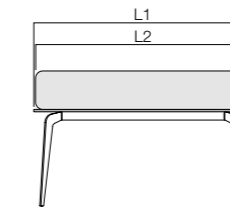
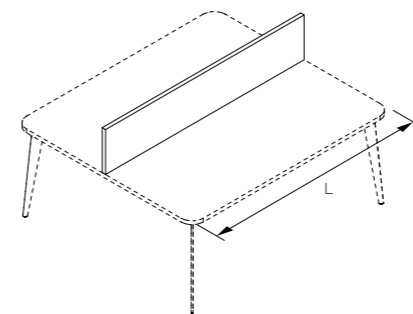

disponibile con 2 o 4 angoli raggiati
available with 2 or 4 rounded corners
disponible avec 2 ou 4 coins ronds
disponible con 2 o 4 cantos redondeados

	L1 120 47 4/16" L2 117 45 15/16"	L1 140 55 2/16" L2 137 53 13/16"	L1 160 63" L2 157 61 11/16"	L1 180 70 14/16" L2 177 69 9/16"	L1 200 78 12/16" L2 197 77 7/16"
	•	•	•	•	•

Screen laterali per bench | *lateral screens for benches* | *écrans latéralux pour bench* | *paneles laterales para bench*

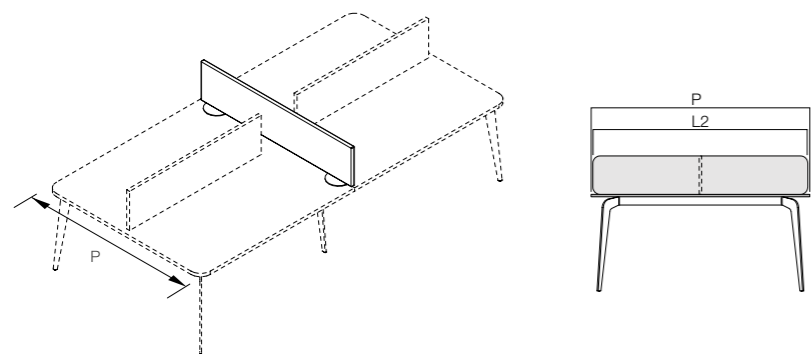

disponibile con 2 o 4 angoli raggati
available with 2 or 4 rounded corners
disponible avec 2 ou 4 coins ronds
disponible con 2 o 4 cantos redondeados

H 73,4 28 14/16"				
	DESK TOP P 160 63" L2 157 61 11/16"			
	•			

Tavoli riunione | *meeting tables* | *tables de réunion* | *mesas de juntas*

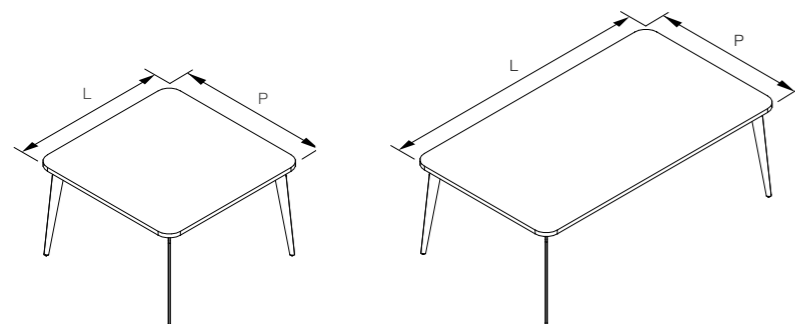

H 73,4 28 14/16"				
	L 120 47 4/16"	L 210 82 11/16"	L 280 110 4/16"	
P 120 47 1/4"	•	•	•	

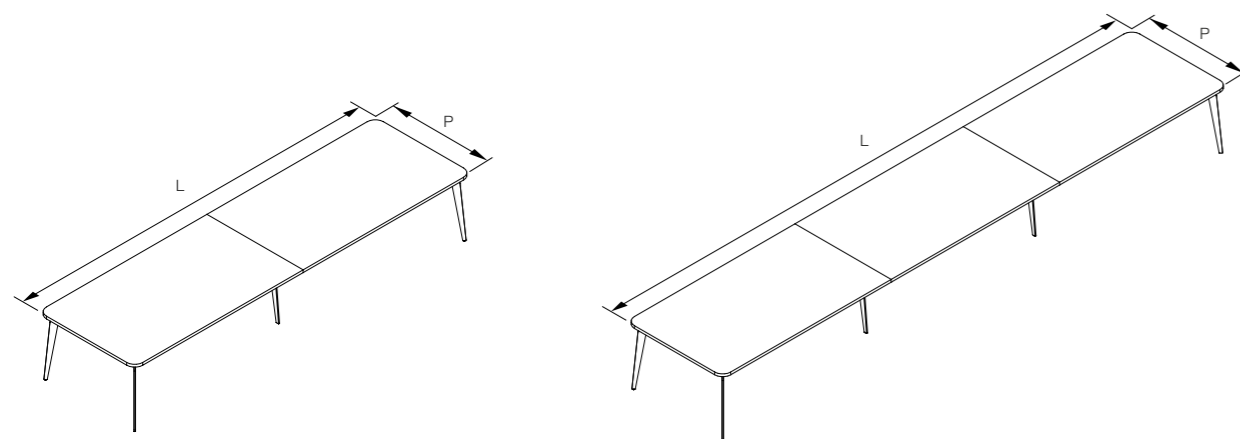

H 73,4 28 14/16"				
	L 420 165 6/16"	L 560 220 8/16"	L 630 248"	
P 120 47 4/16"	•	•	•	

Tavoli riunione rotondi | *round meeting tables* | *tables de réunion rondes* | *mesas de juntas redondas*

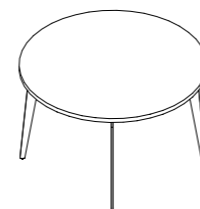

H 73,4 28 14/16"				
	Ø 120 47 4/16"	Ø 150 59 1/16"		
	•	•		

Mobili di servizio su ruote | *mobile service unit with casters* | *meuble retour mobile sur roulettes* | *armarios con ruedas*

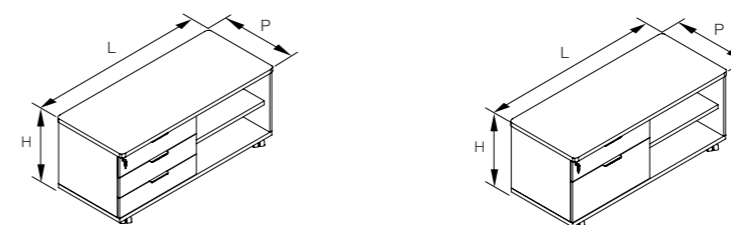

SX

H 63 24 13/16"				
	L 138 54 5/16"			
P 60 23 10/16"	•			

Mobili di servizio fissi | *freestanding service unit* | *meuble retour fixe sur patins* | *armarios con pies*

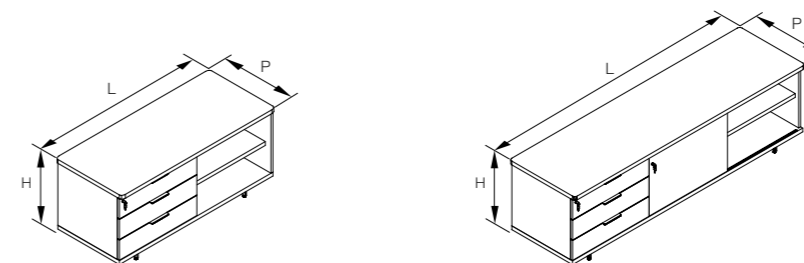

SX

H 63 24 13/16"				
	L 138 54 5/16"	L 207 81 8/16"		
P 60 23 10/16"	•	•		

Mobili di servizio fissi | *feestanding service unit* | *meuble retour fixe sur patins* | *armarios con pies*

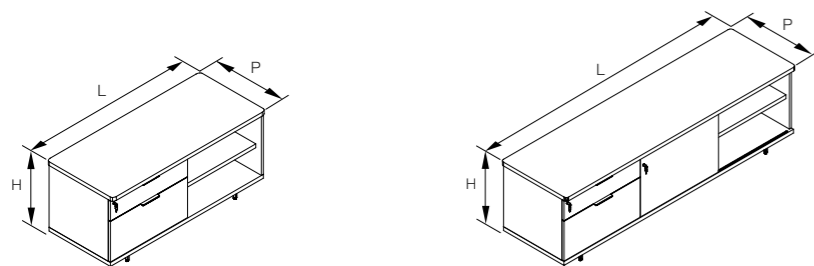

H 63 24 13/16"					
	L 138 54 5/16"	L 207 81 8/16"			
P 60 23 10/16"	•	•			

Credenze | *credenzas* | *rangements* | *armarios*

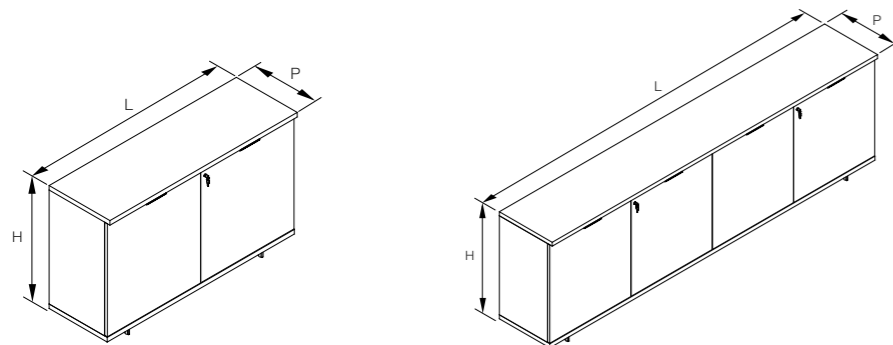

H 89 35 1/16"					
	L 140 55 2/16"	L 280 110 4/16"			
P 45 17 12/16"	•	•			

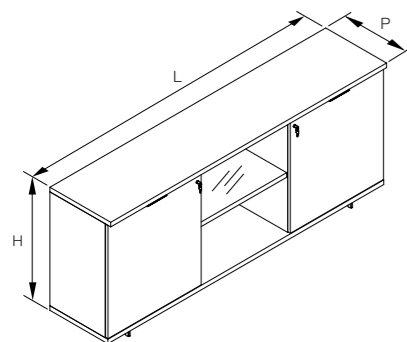

H 89 35 1/16"					
	L 207 81 8/16"				
P 45 17 12/16"	•				

Credenze | *credenzas* | *rangements* | *armarios*

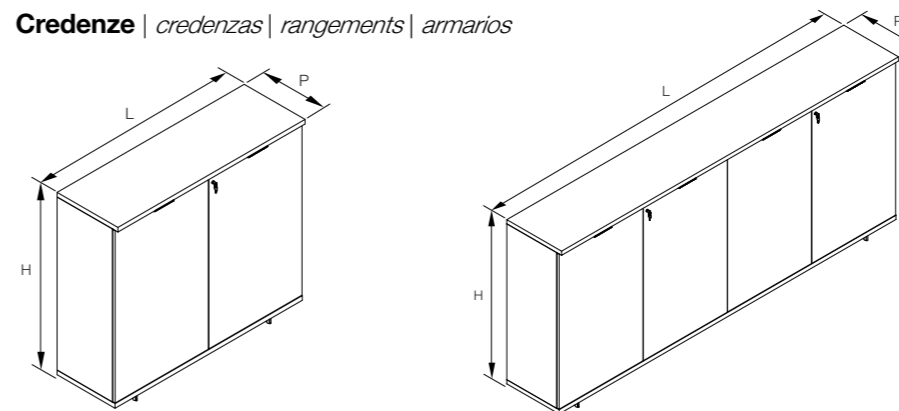

H 127 50"					
	L 140 55 2/16"	L 280 110 4/16"			
P 45 17 12/16"	•	•			

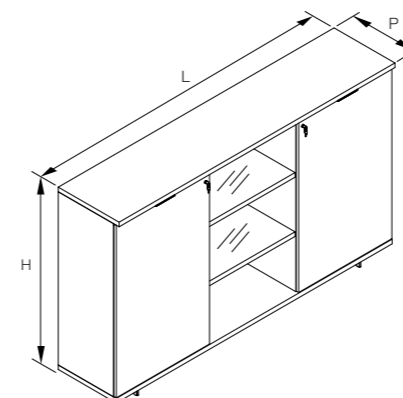

H 127 50"					
	L 207 81 8/16"				
P 45 17 12/16"	•				







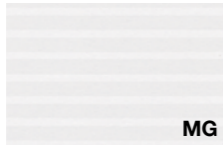
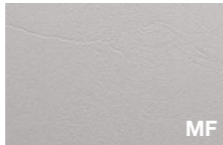

Finiture | Finishes | Finitions | Acabados

MEL

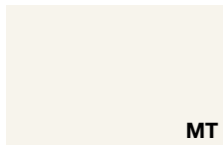
Melaminico

Melamine | Mèlaminé | Melaminico

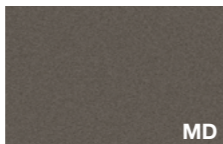

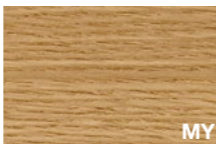
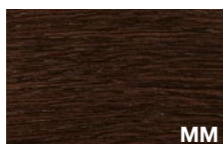
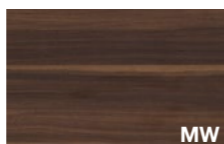



TOP MOB MOD SCR

 Bianco rigato Rippled effect white Blanc avec rayures en sérigraphie Blanco rayado	 Grigio rigato Rippled effect grey Gris avec rayures en sérigraphie Gris rayado	 Nichel Nickel Nickel Niquel	 Cacao Cocoa Cacao Cacao	 Bianco White Blanc Blanco
 Talco Talco Talco Talco	 Ocra Ochre Ocre Ocre	 Safari Safari Safari Safari	 Noisette Noisette Noisette Noisette	 Verde Green Vert Verde
 Nero Black Noir Negro	 Blu notte Night blue Bleu nuit Azul noche	 Ardesia Ardesia Ardesia Pizarra	 Rovere chiaro Light oak Chêne clair Roble claro	 Rovere americano American oak Chêne américain Roble americano
 Rovere grigio Grey oak Chêne gris Roble gris	 Rovere moro Dark oak Chêne foncé Roble oscuro	 Noce Canaletto Canaletto Walnut Noyer Canaletto Nogal Canaletto	 Noce scuro Dark walnut Noyer foncé Nogal oscuro	

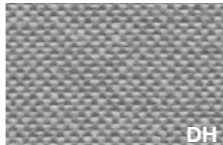
TES

Tessuto

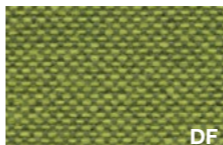
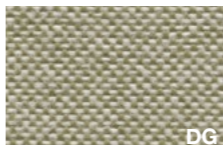



Fabric | Tissu | Tejido

 Beige Beige Beige Beige	 Grigio chiaro Light grey Gris clair Gris claro	 Ardesia Ardesia Ardesia Pizarra	 Blu avio Avio blue Bleu avio Azul avio	 Acquamarina Aquamarine Aigue-marine Aguamarina
 Verde primavera Spring green Vert printemps Verde primavera	 Salvia Sage Sauge Salvia	 Arancio Orange Orange Naranja	 Corallo Coral Corail Coral	

GOF

Goffrato

Embossed | Gaufré | Gofrado

 Bianco White Blanc Blanco	 Argento Silver Argent Plata	 Grigio scuro Dark grey Gris foncé Gris oscuro	 Noisette Noisette Noisette Noisette	 Ardesia Ardesia Ardesia Pizarra
 Moka Mocha Moka Cafe	 Nero Black Noir Negro	 Arancione Orange Orange Naranja	 Rosso "F" Red "F" Rouge "F" Rojo "F"	 Rubino Ruby Rubis Rubi
 Indaco Indigo Indigo Azul Indigo	 Azzurro Blue Bleu Azul	 Verde Green Vert Verde	 Cedro Lime green Vert Cédrat Verde Cedro	

MTC

Metacrilato

Acrylic | Méthacrylate | Metacrilato

SCR

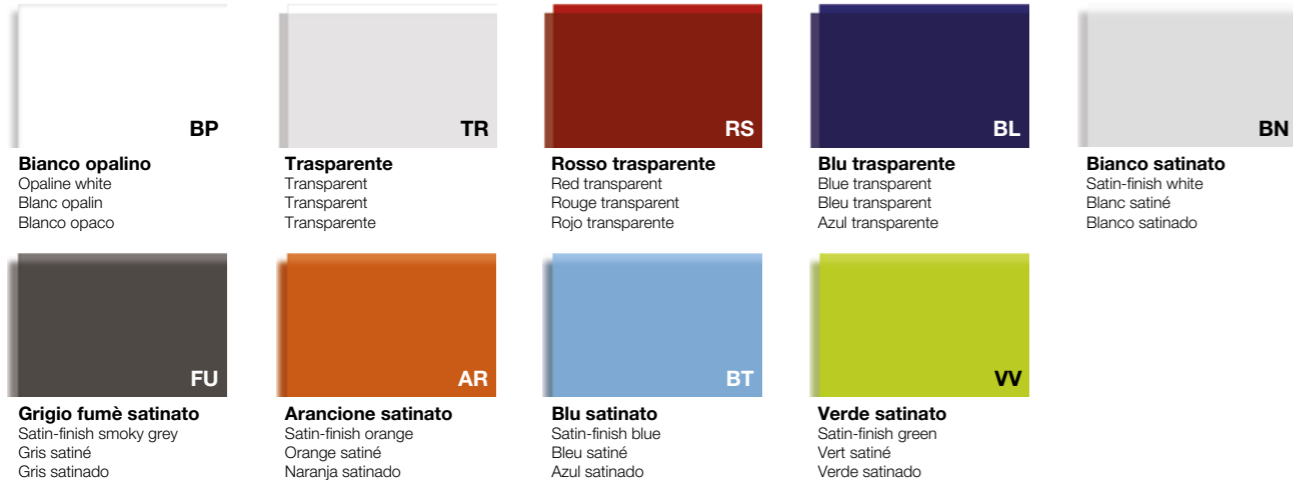

EPX

Epossidico

Epoxy | Époxy | Epoxi

STRU



Applicazioni finiture

Finish application | Application finitions | Aplicacion acabados

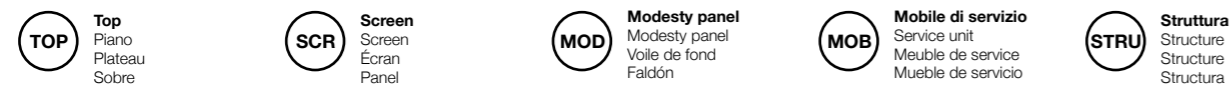

Le finiture contenute nella stampa sono puramente indicative e non sono di riferimento per le forniture del prodotto
Due to the printing process, finishes shown in this document are for illustration only. The finish on the final item may differ slightly from the printed illustration.
Les finitions contenues dans l'impression sont purement indicatives et ne sont pas pertinentes pour les fournitures du produit.
Los acabados contenidos en la impresión son puramente indicativos y no son de referencia para los suministros del producto.

Le immagini dei prodotti visibili all'interno di questo catalogo sono inserite a scopo puramente indicativo
The images of the products visible in this catalogue are included for information purposes only
Les images des produits visibles dans ce catalogue sont incluses à titre informatif uniquement
Las imágenes de los productos visibles en este catálogo se incluyen sólo con fines informativos

Concept, visual & graphic design

Alea marketing + communication

Design

Mirto Antonel

Art direction

Mirto Antonel

Si ringrazia M.artedesign

martedesign.it

AC/CACB/AD



GLOBAL HEADQUARTERS AND SHOWROOM : Via Col de Rust, 19 - 33070 Sarone (PN) - Italia : Tel ++39 0434 777 333
email: info@aleaoffice.com **PARIS SHOWROOM** : 176 Avenue Charles de Gaulle 92200, Neuilly-sur-Seine - France **NORTH AMERICAN**
HEADQUARTERS : Midtown 2, 3449 NE 1st Avenue L-32, Miami, FL 33137 - USA : Tel ++1 305 470 1200 - email: info@alea-usa.com
ALEA UK OFFICE AND SHOWROOM : 50-54 Clerkenwell Road, London EC1M 5PS - email: info@aleaoffice.com